

Airfield Pavement Inlay 1594 X 1053

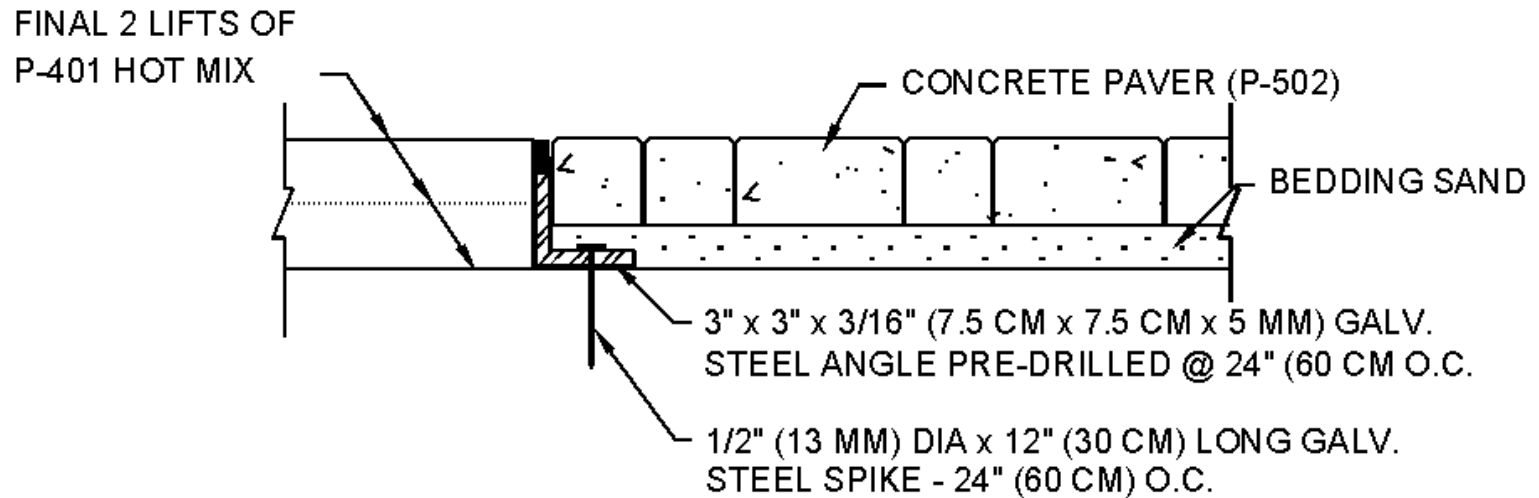

NOTES:

1. CONSTRUCT P-401 OVERLAY APPROX. 2 FT. (60 CM) PAST ANGLE LOCATION AND CUT BACK FOR ANGLE INSTALLATION
2. ADJUST ANGLE LOCATION +/- 2 IN. (5 CM) TO MINIMIZE CUTTING BLOCKS
3. ADD DRAIN HOLES AS NECESSARY AT LOWEST ELEVATIONS. COVER WITH GEOTEXTILE.



Creating elegant hardscaping environments.

118 International Drive, Suite 101
Morrisville, NC 27560

800-292-7220

www.fredadampaving.com